

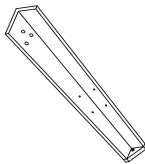





	VRH MIZE					
	<table border="1"> <tr><td> </td></tr> <tr><td> </td></tr> <tr><td> </td></tr> <tr><td> </td></tr> <tr><td> </td></tr> <tr><td> </td></tr> </table>					
 1 x 04-031G-01						

	DESNA NOGA					
	<table border="1"> <tr><td> </td></tr> <tr><td> </td></tr> <tr><td> </td></tr> <tr><td> </td></tr> <tr><td> </td></tr> <tr><td> </td></tr> </table>					
 2 x 04-031G-02						

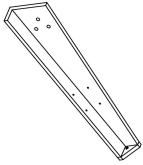

	LEVA NOGA					
	<table border="1"> <tr><td> </td></tr> <tr><td> </td></tr> <tr><td> </td></tr> <tr><td> </td></tr> <tr><td> </td></tr> <tr><td> </td></tr> </table>					
 2 x 04-031G-03						



	KONČNI PANEL NOGE					
	<table border="1"> <tr><td> </td></tr> <tr><td> </td></tr> <tr><td> </td></tr> <tr><td> </td></tr> <tr><td> </td></tr> <tr><td> </td></tr> </table>					
 2 x 04-031G-04						

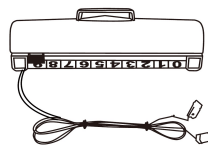

	STRANSKI PANEL NOGE					
	<table border="1"> <tr><td> </td></tr> <tr><td> </td></tr> <tr><td> </td></tr> <tr><td> </td></tr> <tr><td> </td></tr> <tr><td> </td></tr> </table>					
 2 x 04-031G-05						

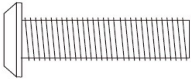

	IZRAVNALNIK NOG					
	<table border="1"> <tr><td> </td></tr> <tr><td> </td></tr> <tr><td> </td></tr> <tr><td> </td></tr> <tr><td> </td></tr> <tr><td> </td></tr> </table>					
 4 x 04-031G-06						

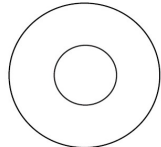

	ELEKTRONSKI ZAPISOVALNIK					
	<table border="1"> <tr><td> </td></tr> <tr><td> </td></tr> <tr><td> </td></tr> <tr><td> </td></tr> <tr><td> </td></tr> <tr><td> </td></tr> </table>					
 1 x 04-031G-07						

	ŠKATLA ZA GOL S SENZORJEM					
	<table border="1"> <tr><td> </td></tr> <tr><td> </td></tr> <tr><td> </td></tr> <tr><td> </td></tr> <tr><td> </td></tr> <tr><td> </td></tr> </table>					
 2 x 04-031G-08						

	VIJAK					
	<table border="1"> <tr><td> </td></tr> <tr><td> </td></tr> <tr><td> </td></tr> <tr><td> </td></tr> <tr><td> </td></tr> <tr><td> </td></tr> </table>					
6 mm x 28 mm  12 x 04-031G-09						

	PRALNI STROJ					
	<table border="1"> <tr><td> </td></tr> <tr><td> </td></tr> <tr><td> </td></tr> <tr><td> </td></tr> <tr><td> </td></tr> <tr><td> </td></tr> </table>					
 12 x 04-031G-10						

	VIJAK					
	<table border="1"> <tr><td> </td></tr> <tr><td> </td></tr> <tr><td> </td></tr> <tr><td> </td></tr> <tr><td> </td></tr> <tr><td> </td></tr> </table>					
3.5 mm x 12 mm  8 x 04-031G-11						

	VIJAK					
	<table border="1"> <tr><td> </td></tr> <tr><td> </td></tr> <tr><td> </td></tr> <tr><td> </td></tr> <tr><td> </td></tr> <tr><td> </td></tr> </table>					
3.5 mm x 14 mm  18 x 04-031G-12						

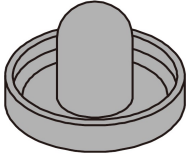

 2 x 04-031G-13	HOKEJSKI POTISKALNIK - MODRA/RDEČA VODILA





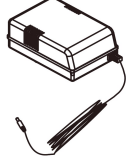

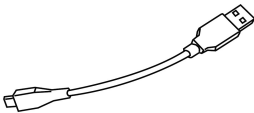
 1 x 04-031G-14	HOKEJSKI PLOŠČEK RDEČE VODIL

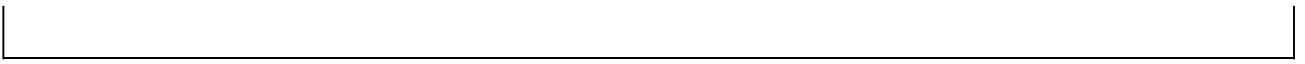
 2 x 04-031G-15	HOKEJSKI PLOŠČEK RDEČE BARVE



 1 x 04-031G-16	ADAPTER

 1 x 04-031G-17	KABEL USB

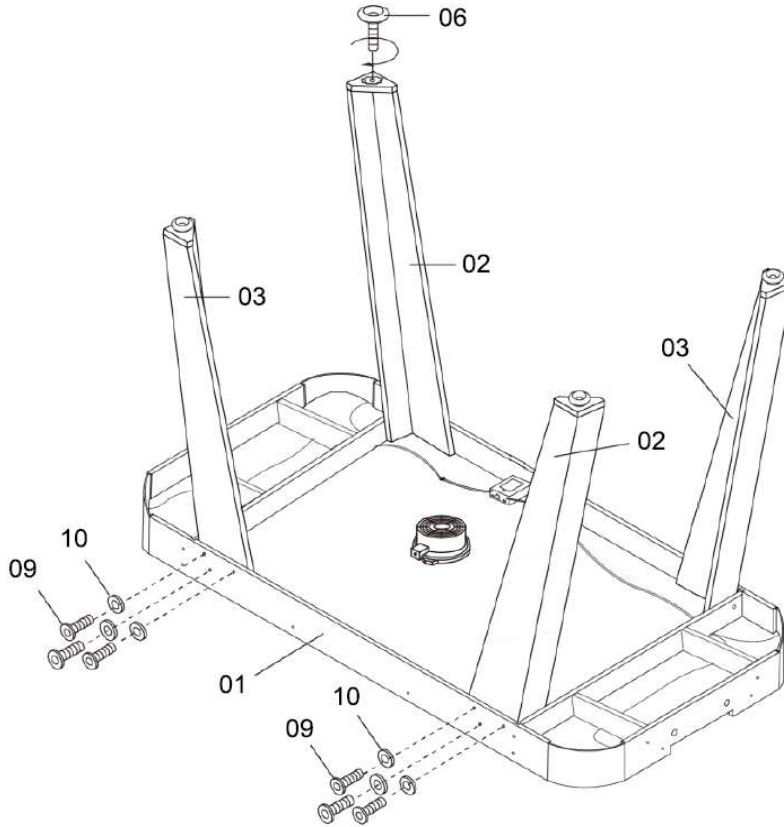

#01		1 X	#02		2 X	#03		2 X
#09		12 X	#10		12 X	#06		4 X



#04		2 X	#05		2 X	#12		16 X
-----	---	-----	-----	---	-----	-----	---	------

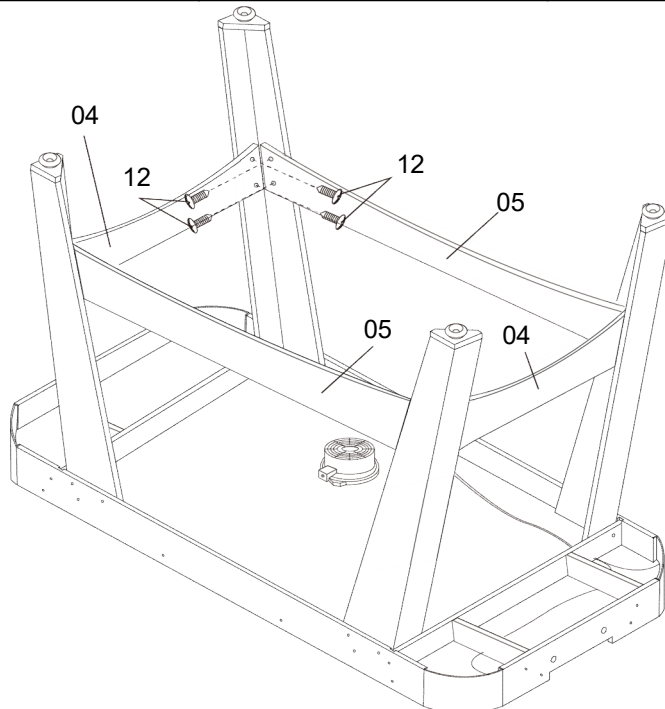

NOTE: Graphic Artwork on the leg panels must face upside down.

REMARQUE : les graphismes sur le panneau d'extrémité de pied doivent être placés à l'envers.

NOTA: la decorazione grafica sul pannello terminale della gamba deve essere rivolta verso il basso.

NOTA: el gráfico del panel lateral de la pata debe estar cabeza abajo.

OPMERKING: de grafische weergave op de poot-eindplaat moet verkeerdom worden aangebracht.

HINWEIS: Die Graphik auf den Bein-Streben muss verkehrt herum angebracht werden

OPOMBA: Grafično delo na ploščah za noge mora biti obrnjeno navzdol.

OPOZORILO: Pri tem koraku sta potrebni dve odrasli osebi. Zelo previdno obrnite mizo in jo postavite na noge. Miza je težka.

#08



2 X

#11



8 X

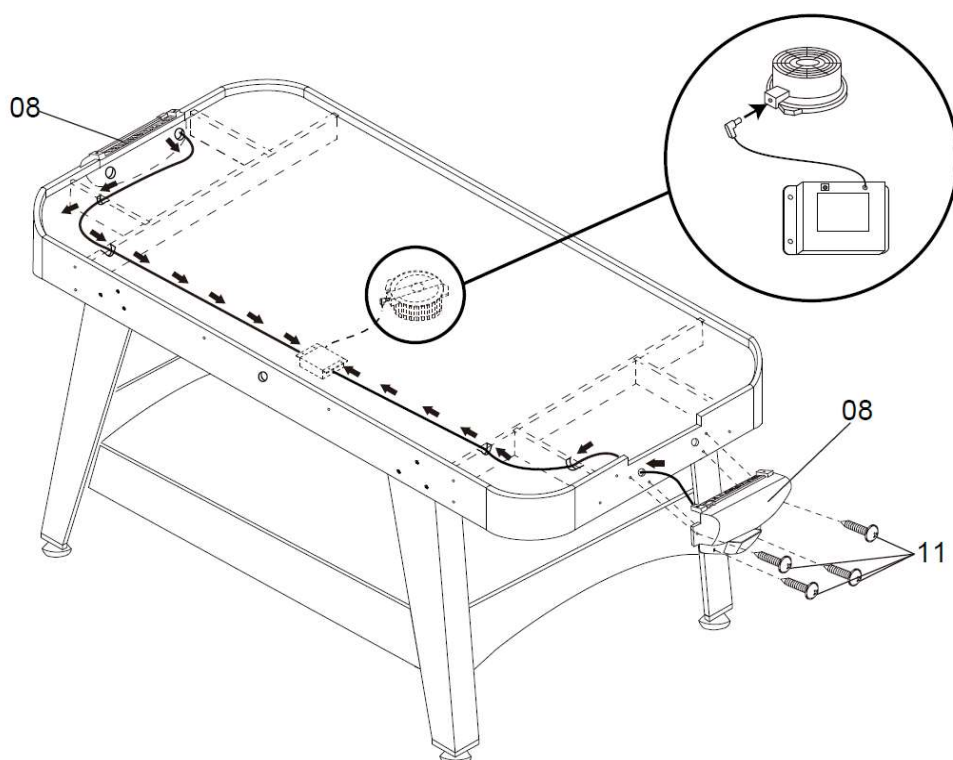

POMEMBNA OPOMBA: rahlo pritisnite na vse priključke, da zagotovite pravilne povezave.

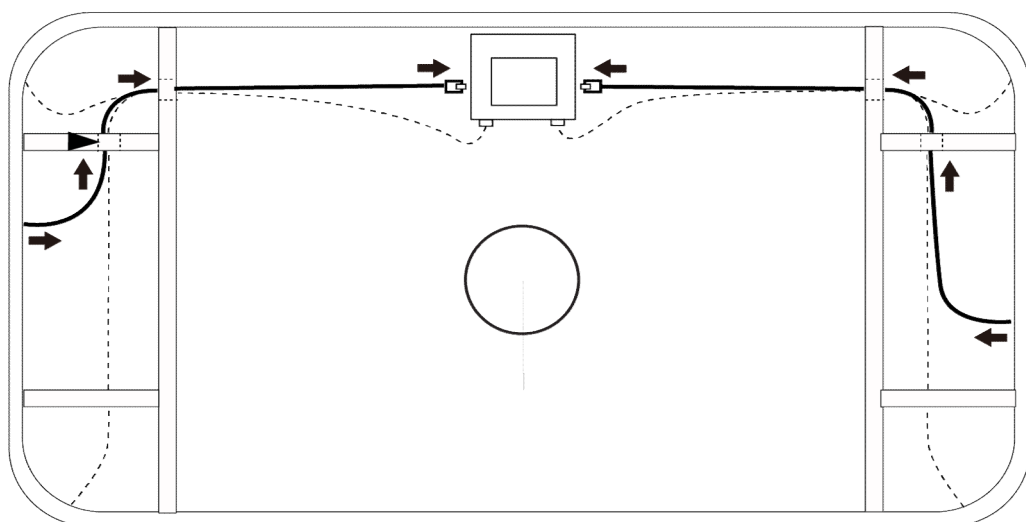



#07



1 x

#12



2 x

#16



1 x

POMEMBNA OPOMBA: previdno obrnite priključek na stran in ga nežno potisnite skozi luknjo v zgornji tirnici. NE PRITISKAJTE NA PRIKLJUČEK S SILO.

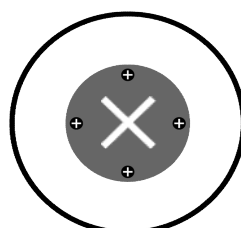
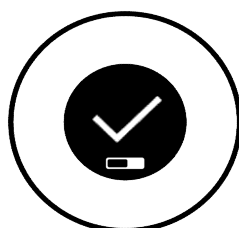
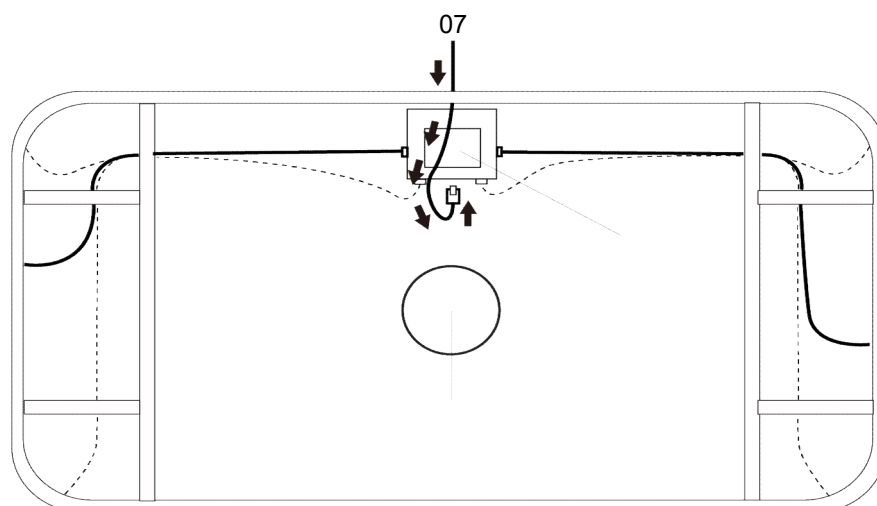
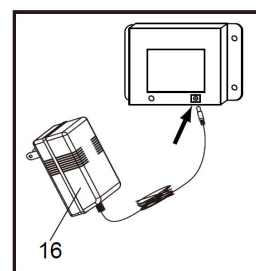
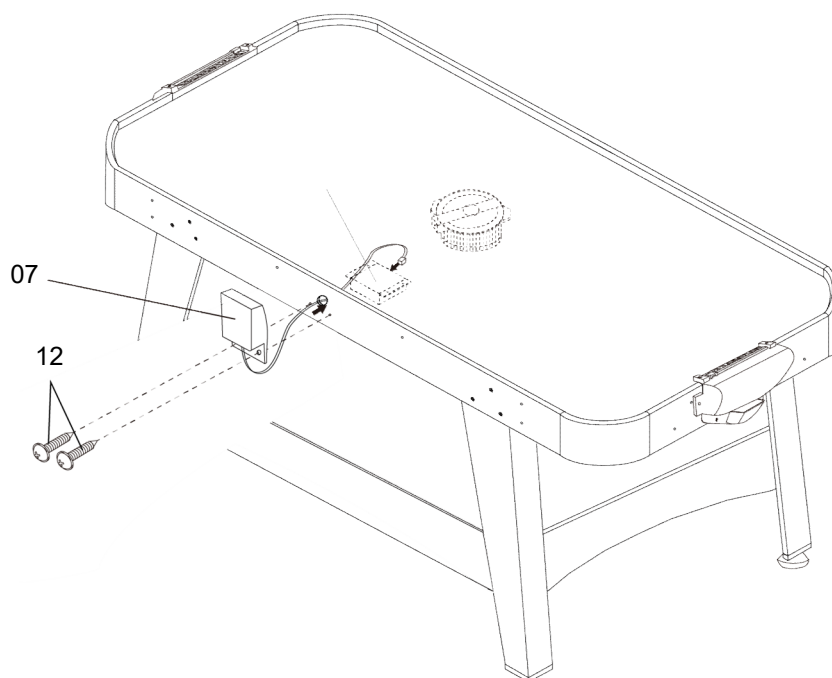

NASVET: Pri igranju s ploščkom LED je ta stran obrnjena navzgor!





ZAMENJAVA BATERIJE LED PUCK - NAVODILA

STEP ONE:

Remove screws and back cap from LED Puck using **Small Phillips Screwdriver** (not provided).

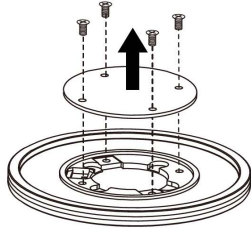

KORAK 1: Z majhnim Philipsovim vijačnikom (ni priložen) odstranite vijake in zadnji pokrovček z LED Puck.

STEP TWO:

Remove CR2016 Lithium Battery 3V from LED Puck.

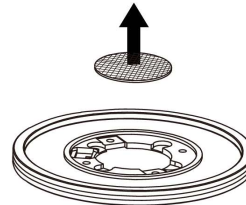

IF BATTERY HOLDER BRACKET MOVES, RE-INSTALL IT TO LED PUCK AS SHOWN IN DIAGRAM.

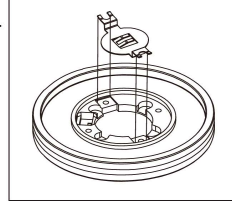

KORAK 2: Odstranite 3V litijevo baterijo CR2016 iz LED Puck

STEP THREE:

Insert new CR2016 Lithium Battery 3V into LED Puck.

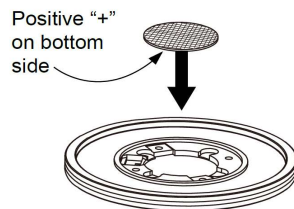

KORAK 3: Vstavite novo 3V litijevo baterijo CR2016 v LED Puck s pozitivnim "+" na spodnji strani.

STEP FOUR:

Install back cap and secure screws with Phillips Screwdriver (not provided).

NOTE:

Make sure the on/off switch on the back cap properly aligns and fits into its slot in the LED puck during reassembly

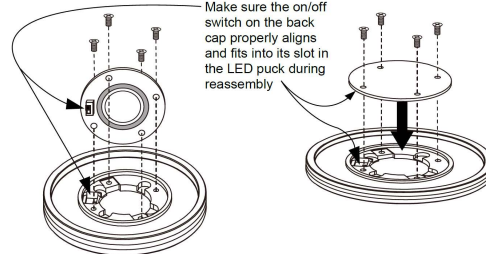

KORAK 4: **OPOMBA:** Preprijčajte se, da je stikalo za vklop/izklop na zadnjem pokrovčku pravilno poravnano in se med ponovno montažo prilega reži v ploščici LED.

OPOZORILO - BATERIJE HRANITE ZUNAJ DOSEGA OTROK Zaradi kemičnih opeklin in morebitne perforacije požiralnika lahko požiranje povzroči hude poškodbe že v 2 urah ali smrt. Preglejte naprave in se preprijčajte, da je prostor za baterije pravilno zavarovan, npr. da je vijak ali drug mehanski pritrdilni element zategnjen. Če predal ni zavarovan, ga ne uporabljajte. Izrabljene gumbaste baterije takoj in varno zavrzite. Prazne baterije so lahko še vedno nevarne. **OPOZORILO:** Ta izdelek vsebuje baterijo s kovancem. Kovinska baterija lahko ob zaužitju povzroči hude notranje kemične opekline. Opozorilo: Uporabljene baterije takoj zavrzite. Nove in uporabljene baterije hranite stran od otrok. Če menite, da ste baterije morda pogoltnili ali jih namestili v katerikoli del telesa, takoj poiščite zdravniško pomoč. Ta igrača vsebuje baterije, ki jih ni mogoče zamenjati.



POLNENJE LED POTISNE BATERIJE - NAVODILA

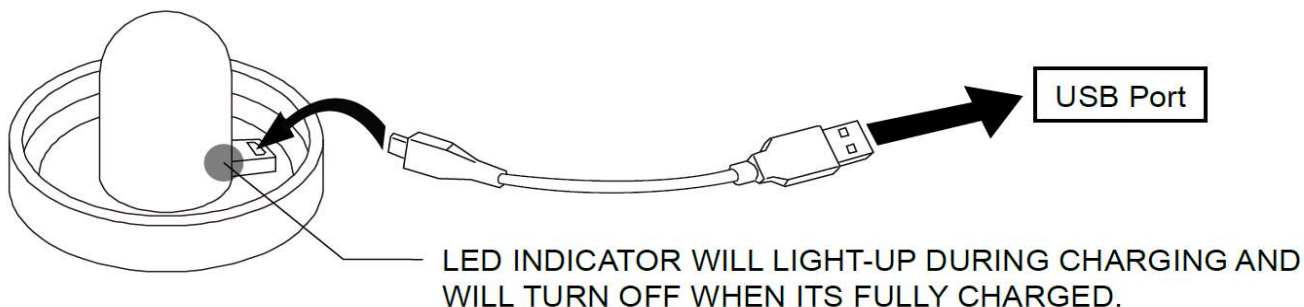

LED INDIKATOR SE MED POLNENJEM PRIŽGE IN UGASNE, KO JE POPOLNOMA NAPOLNJEN.



NASVET: Vsak od LED-strikerjev potrebuje približno 4 ure, da se popolnoma napolni, in traja približno 7 ur neprekinjenega igranja. **Ko ne uporabljate ali ko se polnijo, stikalo prestavite v položaj "OFF" (izklopljeno).**

NASVET: Baterija ploščka LED zdrži približno 7 ur neprekinjenega igranja. Baterije ploščka ni mogoče ponovno napolniti. Ko stikala ne uporabljate, ga obrnite v položaj "OFF", da ohranite življenjsko dobo baterije.

